

Model: Kir-C2 GW Expansion Unit (B658)	Date: 6-Jul-04	No.: MB658001
--	----------------	---------------

Modified Article: Parts Catalog Correction		Prepared by: M. Ishihara	
From: 1 st Tech. Support Sec. Service Support Dept.			
Reason for Modification:	<input checked="" type="checkbox"/> Parts catalog correction	<input type="checkbox"/> Vendor change	<input type="checkbox"/> To meet standards ()
	<input type="checkbox"/> To facilitate assembly	<input type="checkbox"/> To improve reliability	
	<input type="checkbox"/> Part standardization	<input type="checkbox"/> Other	

Please correct your Parts Catalogs as follows:

Page 2 and 3

- Addition -

Part number	Description	Q'ty	Index	Note
B6201461	Fax Decal – NA ASIA	1	20	
B6201450	Fax Cover EU	1	21	
B6201421	Fax Cover NA	1	21	
B6581455	Expansion Sheet	1	22	

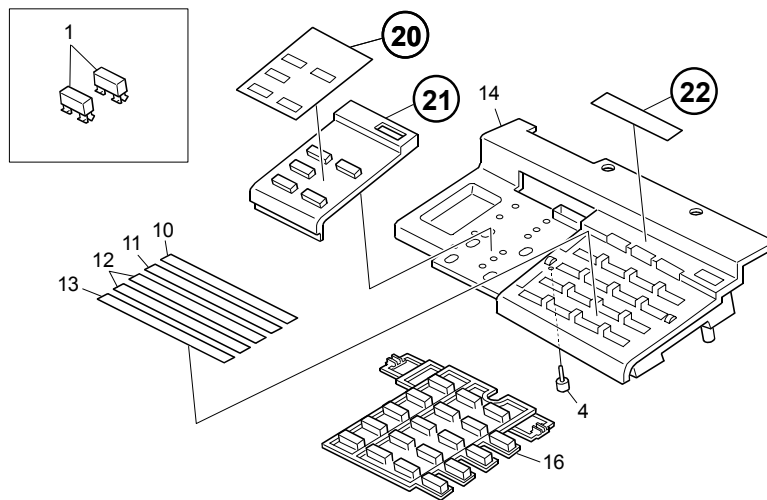

Model: Kir-C2 GW Expansion Unit (B658)		Date: 20-Jul-04	No.: MB658002
Modified Article: Fax Cover		Prepared by: M. Ishihara	
From: 1 st Tech. Support Sec. Service Support Dept.			
Reason for Modification:	<input type="checkbox"/> Parts catalog correction <input type="checkbox"/> To facilitate assembly <input type="checkbox"/> Part standardization	<input type="checkbox"/> Vendor change <input checked="" type="checkbox"/> To improve reliability <input type="checkbox"/> Other	<input type="checkbox"/> To meet standards ()

Please note the following changes:

1. A vinyl bag was added to the Fax Cover for more protection.
Note: This is the only difference, so both the new and old parts can be used in the field.
2. The page number for the Fax Cover was corrected:
 Incorrect: pg. 12
Correct: pg. 3

Old part number	New part number	Description	Q'ty	Int	Page	Index	Note
B6201421	B6201415	Fax Cover NA	1-1	O/O	3	21	
B6201450	B6201422	Fax Cover EU	1-1	O/O	3	21	

NOTE: The first P/N for the Fax Cover was announced in MB658001.

Model: Kir-C2 GW Expansion Unit (B658)	Date: 22-Apr-05	No.: MB658003
--	-----------------	---------------

Modified Article: PCB Ct I: Exp : Ass'y		Prepared by: M. Ishihara	
From: 1 st Tech. Support Sec. Service Support Dept.			
Reason for Modification:	<input type="checkbox"/> Parts catalog correction	<input type="checkbox"/> Vendor change	<input type="checkbox"/> To meet standards ()
	<input type="checkbox"/> To facilitate assembly	<input checked="" type="checkbox"/> To improve reliability	
	<input type="checkbox"/> Part standardization	<input type="checkbox"/> Other	

Old part number	New part number	Description	Q'ty	Int	Page	Index	Note
B6585700	B6585701	PCB Ct I: Exp : Ass'y	1-1	X/O	5	2	

Change: A jumper wire was added and a resistor (R524) was removed from the controller board.

Reason: To improve the power distribution to the Piccolo ASIC.

Note: This change was applied to the machine production line from October 2004.